

AZSR190

90/100 AMP POWER RELAY

FEATURES

- Up to 100 Amp switching capability
- Wide contact gap of ≥ 3.6 mm
- Clearance and creepage of ≥ 10 mm
- 5 kV dielectric strength, 10 kV surge withstand voltage
- UL Class F insulation (155°C)
- UL E365652
- TÜV B0887930008
- CQC 17002178200



CONTACTS

Arrangement	SPST-N.O. (1 Form A)
Ratings (max.) standard version switched power switched current high current version switched power switched current switched voltage	(resistive load) 44000 VA 90 A 69000VA 100 A 800 VAC
Rated Loads UL/CUR/	55A at 480 VAC, resistive, 85°C, 30k cycles ^[1] 55A at 690 VAC, resistive, 85°C, 20k cycles ^[1] 55A at 800 VAC, resistive, 85°C, 1k cycles ^{[1][2]} 55A at 690 VAC, resistive, 85°C, 30k cycles ^[2] 80A at 277 VAC, resistive, 85°C, 10k cycles ^[2]
high current version	100A at 480 VAC, resistive, 85°C, 1k cycles ^[1] 100A at 690 VAC, resistive, 85°C, 1k cycles ^[2]
TÜV/CQC	30A at 480 VAC, resistive, 85°C, 50k cycles ^[1] 55A at 480 VAC, resistive, 85°C, 30k cycles ^[1] 55A at 690 VAC, resistive, 85°C, 20k cycles ^[1] 55A at 690 VAC, resistive, 85°C, 30k cycles ^[2] 55A at 800 VAC, resistive, 85°C, 1k cycles ^{[1][2]} 80A at 277 VAC, resistive, 85°C, 10k cycles ^[2] 90A at 480 VAC, resistive, 85°C, 1k cycles ^[1]
high current version	100A at 480 VAC, resistive, 85°C, 1k cycles ^[1] 100A at 690 VAC, resistive, 85°C, 1k cycles ^[2]
Contact material	AgNi - silver nickel ^[1] AgSnO ₂ - silver tin oxide ^[2]
Contact gap	≥ 3.6 mm
Contact resistance Initial	(load contact) ≤ 100 m Ω (at 6V, 1A, voltage drop method) ≤ 10 m Ω (at 10A, voltage drop method)
typical	< 3 m Ω (at 6V, 1A, voltage drop method)

COIL

Nominal coil DC voltages	6, 9, 12, 24,
Dropout voltage	$\geq 5\%$ of nominal coil voltage
Holding voltage	$\geq 40\%$ of nominal coil voltage
Coil power nominal holding power at pickup voltage	(at 23 °C) 1.9 W 310mW 1.1 W
Temperature Rise	70 K at nom. coil voltage, 85°C
Max. temperature	Class F insulation - 155°C (311°F)

GENERAL DATA

Life Expectancy mechanical electrical	(minimum operations) 1×10^6 see UL/CUR/TÜV/CQC ratings
Operate Time	40 ms (max.) at nominal coil voltage
Release Time	10 ms (max.) at nominal coil voltage, without coil suppression
Dielectric Strength coil to load contacts open load contacts	(at sea level for 1 min.) 5000 V _{RMS} 2500 V _{RMS}
Surge Voltage coil to contacts	10kV (at 1.2 x 50 μ s)
Insulation Resistance	1000 M Ω (min.) at 23°C, 500 VDC, 50% RH
Creepage coil to contact	≥ 10.0 mm
Clearance coil to contact	≥ 10.0 mm
Temperature Range operating	(at nominal coil voltage) -40°C (-40°F) to 85°C (185°F)
Vibration resistance	0.062" (1.5 mm) DA at 10–55 Hz
Shock	10 g
Enclosure protection category material group flammability	PBT(Case) and PA46(Base) RT II, flux proof Illa UL94 V-0
Terminals	Tinned copper alloy, P. C.
Soldering max. temperature max. time	270 °C (518°F) 5 seconds
Dimensions length width height standard version low profile version	38.0 mm (1.50") 33.0 mm (1.30") 43.0 mm (1.69") 41.5 mm (1.63")
Weight	85 grams (approx.)
Compliance	UL 508, IEC 61810-1, RoHS, REACH
Packing unit in pcs	10per plastic tube / 150 per carton box

ZETTLER

AZSR190

COIL VOLTAGE SPECIFICATIONS

Nominal Coil VDC	Must Operate VDC	Min. Holding VDC	Max. Cont. VDC	Resistance Ohm \pm 10%
6	4.5	2.4	6.6	18.8
9	6.75	3.6	9.9	42.2
12	9	4.8	13.2	75
24	18	9.6	26.4	300

Note: All values at 23°C (73°F), upright position, terminals downward.

ORDERING DATA

AZSR190 -1A - D

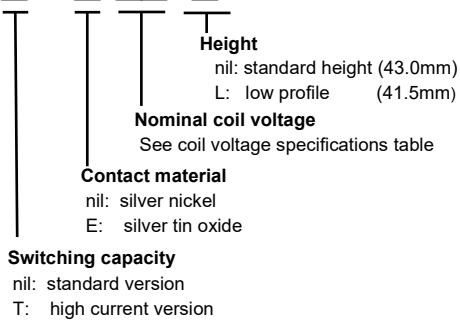

Example ordering data

AZSR190-1A-12DL	Standard version, contact material: silver nickel, 12 VDC nominal coil voltage, low profile
AZSR190T-1A-12D	High current version, contact material: silver nickel, 12 VDC nominal coil voltage, standard height
AZSR190-1AE-9DL	Standard version, contact material: silver tin oxide, 9 VDC nominal coil voltage, low profile

WIRING DIAGRAMS

Viewed towards terminals.
 Note: Provide sufficient PCB cross section on load terminals. Recommended cross section according to IEC 61810-1 at 90A is 35 mm²

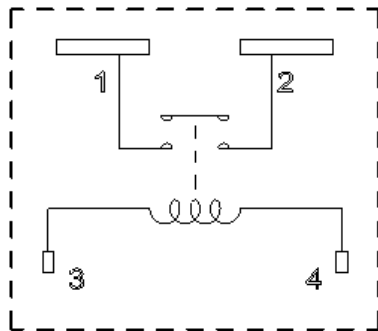

MECHANICAL DATA

Dimensions in mm. Tolerance: \pm 0.5mm

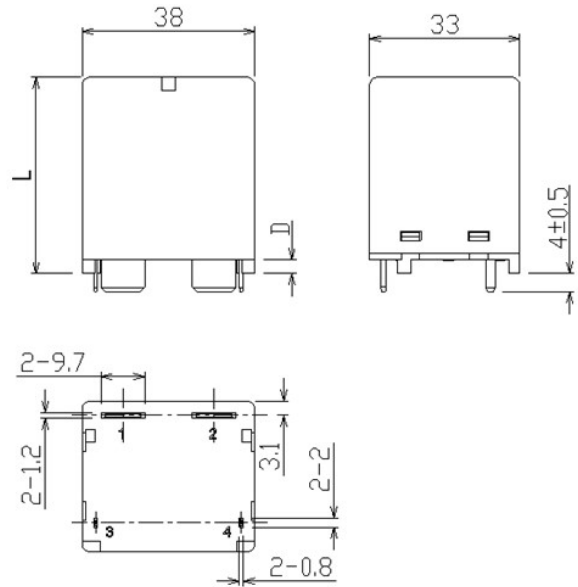

Version	L	D
Standard	43.0	3.0
Low profile	41.5	1.5

PC BOARD LAYOUT

Dimensions in mm. Tolerance: \pm 0.1mm unless otherwise stated
 Viewed towards terminals.

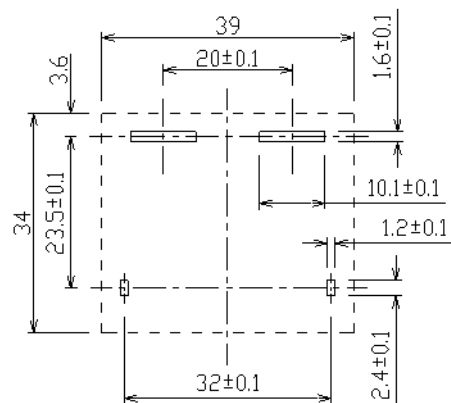

NOTES

General

1. All values in this datasheet are at reference temperature of 23°C (73°F) unless stated otherwise.
2. Evaluate the component's performance and operating conditions under the worst-case conditions of the actual application.
3. The datasheet and the component's specifications are subject to change without notice.

Storage, handling, and environmental guidelines

4. Relays are electromechanical components that are sensitive to shock. The relay's adjustment can be affected if the relay is subjected to excessive shock or excessive pressure is applied to the relay case. Relays which have been dropped must no longer be used.
5. Substances containing silicone or phosphorus must be avoided in the vicinity to the relay. Outgassing from these substances can penetrate the relay and adhere on the contacts. Deposits of these substances may act as insulators and adversely affect the contact resistance. Silicone can be found e.g. in gaskets, lubricants or filling materials, phosphorus can be found e.g. as a flame retardant in plastics.
6. Prevent relays from atmospheres containing corrosive gases or liquid or solid. Corrosion of structures and contacts leads to malfunction and shortens the component's service life.
7. Prevent non-sealed relays from atmospheres subject to dust. Dust particles may enter the case and get stuck between the contacts, causing the contact circuits to fail.
8. Do not use these relays in environments with explosive or flammable gases. Electrical arcing at the contacts could ignite these gases and cause fire.
9. For automated dual wave soldering process we recommend preheating with 120°C (248°F) for max. 120 seconds and a soldering temperature of 260 ±5°C (500 ±9°F) for max. 10 seconds soldering time (max. 5 seconds per wave). For manual soldering we recommend 350°C (662°F) max. temperature for max. 5 seconds. During the soldering process, no force may be exerted on the relay terminals.
10. Non-sealed relays (RTII) must not be washed, immersion cleaned or conformal coated as substances may enter the case and cause corrosion or seizure of mechanical parts.
11. Avoid high frequency or ultrasonic vibrations on the relays as these can cause contact welding and misalignment or destruction of internal structures.
12. During operation, storage and transport, ambient temperature should be within the specified operating temperature range. Humidity should be in the range of 5% to 85% RH. Icing and condensation must be avoided. Relays stored for an extended period of time may show initially increased contact resistance values due to chemical effects such as oxidation.

Design guidelines

13. The relay may pull in and operate with less than the specified *must operate* voltage value.
14. The coil's *must operate* and *min. holding* voltages, the coil's *ohmic resistance* and the relay's *operate time* depend on the temperature of the coil. The specified values are given for a coil temperature of 23°C and increase by approx. 0.39% per Kelvin of temperature rise. This circumstance must be considered, especially during operation with high load currents and elevated ambient temperature.
15. At elevated ambient temperatures, after applying the rated nominal coil voltage for ≥ 200 milliseconds, the coil energization must be reduced to a suitable holding level in order to reduce thermal stress and to prevent the coil from overheating.
16. Coil suppression circuits such as diodes, etc. in parallel to the coil will lengthen the release time. We recommend using suppression circuits with a breakdown voltage of approx. 2 times the nominal coil voltage in order to achieve a quick release time.
17. When using PWM coil control, use a fast-switching recirculation diode in parallel with the coil to keep the coil current during pulse pauses. To achieve a quick release time when de-energizing the coil, the recirculation diode must be eliminated from the circuit to get a fast decay of coil current. As PWM frequency we recommend ≥ 15 kHz in order to avoid audible noise from magnetostriction. To reduce negative EMI effects, we recommend to apply the PWM to the coil's inner/center layer terminal and have the outer layer terminal connected to ground or the supply rail.
18. Contact resistance is a function of load current, dwell time and wear level of the contacts. Immediately after closing the contacts, or if tested with low current only, the contact resistance will show a relatively high value. A low level steady state contact resistance is reached at higher current after a certain time in thermal equilibrium.
19. The relay dissipates heat from power losses through its load terminals. Provide sufficient cross section and area of the PCB traces so that they can act as heat spreader.
20. For PCBs with multiple relays, do not place the components directly next to each other. We suggest providing a mounting distance of minimum 10 mm to allow for better cooling.
21. A minimum load of 10 mA / 5 V / 50 mW is recommended for the gold plated NC signal contact to ensure a reliable and stable electrical connection.
22. As with any contact mechanism, the relay's NC signal contact bounces when switching. For evaluation of its signal, suitable debouncing measures must be taken to get a reliable signal.

AZSR190

DISCLAIMER

This product specification is to be used in conjunction with the application notes which can be downloaded from the regional ZETTLER relay websites. The specification provides an overview of the most significant part features. Any individual applications and operating conditions are not taken into consideration. It is recommended to test the product under application conditions. Responsibility for the application remains with the customer. Proper operation and service life cannot be guaranteed if the part is operated outside the specified limits.

ZETTLER GROUP

Building on a foundation of more than a century of expertise in German precision engineering, ZETTLER Group is a world-class enterprise, engaged in the design, manufacturing, sales and distribution of electronic components. Our industry leadership is based on a unique combination of engineering competence and global scale.

For more information on other ZETTLER Group companies, please visit zettler-group.com. For support on this product or other ZETTLER relays, please visit one of the group sites below.

SITES FOR ZETTLER RELAYS

NORTH AMERICA

American Zettler, Inc.
www.azettler.com
sales@azettler.com

EUROPE

Zettler Electronics, GmbH
www.zettlerelectronics.com
office@zettlerelectronics.com

Zettler Electronics, Poland
www.zettlerelectronics.pl
office@zettlerelectronics.pl

CHINA

Zettler Group, China
www.zettlercn.com
relay@zettlercn.com

ASIA PACIFIC

Zettler Electronics (HK) Ltd.
www.zettlerhk.com
sales@zettlerhk.com



ZETTLER