

AZEV132

32 AMP POWER RELAY

FEATURES

- 32 Amp nominal switching capability
- Isolated NC signal contact for welding monitoring
- Withstands up to 1500 A short circuit current
- Wide contact gap of ≥ 2.25 mm
- Dielectric strength 4 kVAC
- UL / CUR: E365652
- TÜV: B 088793 0014
- CQC: CQC19002216104



CONTACTS

Arrangement load contact signal contact	SPST-NO (1 Form A) SPST-NC (1 Form B) coupled to load contact
Ratings (max.) load contact switched power switched current switched voltage signal contact switched current minimum load	(resistive load) 12800 VA 40 A 400 VAC 10 mA at 12 VDC 10 mA, 5 VDC, 50mW
Rated Loads UL/CUR load contact signal contact TÜV load contact signal contact CQC load contact signal contact	32 A at 277 VAC, resistive, 85°C, 50k cycles 40 A at 277 VAC, resistive, 45°C, 6k cycles 10 mA at 12 VDC, 85°C, 50k cycles 32 A at 400 VAC, resistive, 85°C, 50k cycles 40 A at 277 VAC, resistive, 85°C, 10k cycles 10 mA at 12 VDC, 85°C, 50k cycles 32 A at 400 VAC, resistive, 85°C, 50k cycles 40 A at 277 VAC, resistive, 45°C, 6k cycles 10 mA at 12 VDC, 85°C, 50k cycles
Contact material load contact signal contact	AgSnO ₂ (silver tin oxide) AgNi + Au (silver nickel, gold plated)
Contact gap load contact	≥ 2.25 mm
Contact resistance load contact initial typical	≤ 50 m Ω < 3 m Ω

COIL

Nominal coil DC voltages	5, 9, 12, 24, 48
Dropout voltage	$> 5\%$ of nominal coil voltage
Holding voltage	$> 35\%$ of nominal coil voltage
Coil power nominal holding power at pickup voltage	(at 23 °C) 1.55 W 190 mW 875 mW
Temperature rise	70 K at nom. coil voltage, 85°C
Insulation system	class F, max. temperature 155°C (311°F)

GENERAL DATA

Life Expectancy mechanical electrical	(minimum operations) 1×10^5 see UL/CUR/TÜV/CQC ratings
Operate Time	30 ms (max.) at nominal coil voltage
Release Time	10 ms (max.) at nominal coil voltage, without coil suppression
Dielectric Strength open load contacts coil to load contacts open signal contacts coil to signal contacts signal to load contacts	(at sea level for 1 min.) 2500 V _{RMS} 4000 V _{RMS} 500 V _{RMS} 500 V _{RMS} 4000 V _{RMS}
Pulse current capability	$\geq 1,50$ kA; ≥ 6.0 kA ² s (based on requirements of IEC 62752)
Surge voltage open load contacts coil to load contacts signal to load contacts	6 kV 6 kV 6 kV
Insulation Resistance	1000 M Ω (min.) at 23°C, 500 VDC, 50% RH
Temperature Range operating	(at nominal coil voltage) -40°C (-40°F) to 85°C (185°F)
Vibration resistance	0.062" (1.5 mm) DA at 10–55 Hz
Enclosure protection category material group flammability	P.B.T. polyester RT II, flux proof IIIa UL94 V-0
Terminals	Tinned copper alloy, P. C.
Soldering preheating soldering	(referring IEC 61760-1 wave soldering) 120°C (248°F) / ≤ 120 s 260 ± 5 °C (500 ± 9 °F) / ≤ 10 s
Dimensions length width height	35.0 mm (1.38") 16.0 mm (0.63") 27.9 mm (1.10")
Weight	35 grams (approx.)
Compliance	UL 508, IEC 61810-1, GB/T 21711.1-2008 RoHS, REACH designed to meet requirements of IEC 62752
Agency Approvals UL / CUR TÜV CQC	E365652 B 088793 0014 CQC19002216104
Packing unit in pcs	50 per plastic tray 400 per carton box

ZETTLER

AZEV132

COIL VOLTAGE SPECIFICATIONS

Nominal Coil VDC	Must Operate VDC	Min. Holding VDC	Max. Coil VDC	Resistance Ohm $\pm 10\%$
5	3.75	1.75	6.0	16.15
9	6.75	3.15	10.8	52.3
12	9.0	4.2	14.4	93.0
24	18.0	8.4	28.8	372
48	36.0	16.8	57.6	1488

Test conditions: 23°C (73°F), upright position, terminals downward.

ORDERING DATA

AZEV132-1AE□□□-□□□D

Nominal coil voltage
see coil voltage specifications table

Signal contact

nil: without signal contact
1BG: equipped with 1 Form B signal contact

Example ordering data

AZEV132-1AE-24D Without signal contact, 24 VDC coil

AZEV132-1AE1BG-12D With 1 Form B signal contact, 12 VDC coil

MECHANICAL DATA

Dimensions in mm. Tolerance: ± 0.3 mm if not stated otherwise.
Pin dimensions given without tin coating.
Note: * Pins only present at versions with signal contact.

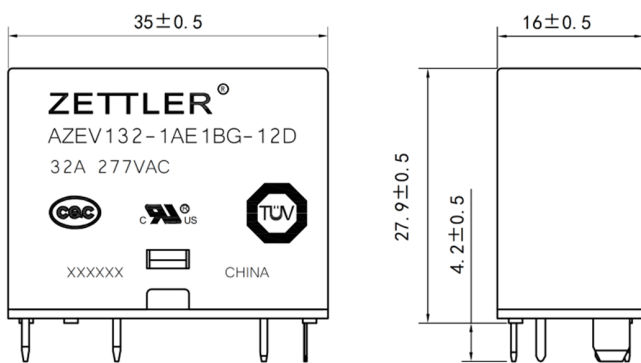
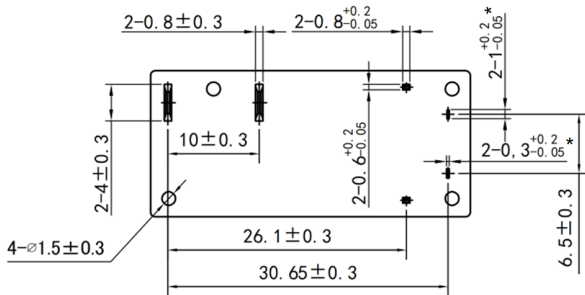

CAD data in attachment of the datasheet.

PC BOARD LAYOUT / WIRING DIAGRAMS

Layout and footprint recommendation. Viewed towards terminals. Dimensions in mm.
Note: * Pins only present at versions with signal contact.

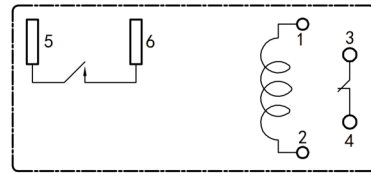
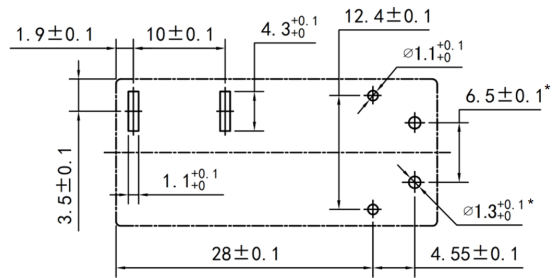

IEC 62752 / IEC 62955 Short Circuit Withstand



Compliance with IEC 62752, IEC 62955 or similar standards for short circuit withstand is a function of both relay design and PCB layout. ZETTLER's relay design and applications engineering teams have developed an application note that contains important design suggestions to optimize the performance of the relay with respect to its short circuit current withstand capability.

In addition, as the overall performance depends on multiple factors such as part arrangement and trace routing, compliance cannot be generically guaranteed by ZETTLER. We strongly encourage customers to conduct their own short circuit tests in accordance with IEC 62752, IEC 62955 or similar standards in the context of their individual application design.

NOTES

General

1. All values in this datasheet are at reference temperature of 23°C (73°F) unless stated otherwise.
2. Evaluate the component's performance and operating conditions under the worst-case conditions of the actual application.
3. The datasheet and the component's specifications are subject to change without notice.

Storage, handling, and environmental guidelines

4. Relays are electromechanical components that are sensitive to shock. The relay's adjustment can be affected if the relay is subjected to excessive shock or excessive pressure is applied to the relay case. Relays which have been dropped must no longer be used.
5. Substances containing silicone or phosphorus must be avoided in the vicinity to the relay. Outgassing from these substances can penetrate the relay and adhere on the contacts. Deposits of these substances may act as insulators and adversely affect the contact resistance. Silicone can be found e.g. in gaskets, lubricants or filling materials, phosphorus can be found e.g. as a flame retardant in plastics.
6. Prevent relays from atmospheres containing corrosive gases or liquid or solid. Corrosion of structures and contacts leads to malfunction and shortens the component's service life.
7. Prevent non-sealed relays from atmospheres subject to dust. Dust particles may enter the case and get stuck between the contacts, causing the contact circuits to fail.
8. Do not use these relays in environments with explosive or flammable gases. Electrical arcing at the contacts could ignite these gases and cause fire.
9. For automated dual wave soldering process we recommend preheating with 120°C (248°F) for max. 120 seconds and a soldering temperature of 260 ±5°C (500 ±9°F) for max. 10 seconds soldering time (max. 5 seconds per wave). For manual soldering we recommend 350°C (662°F) max. temperature for max. 5 seconds. During the soldering process, no force may be exerted on the relay terminals.
10. Non-sealed relays (RTII) must not be washed, immersion cleaned or conformal coated as substances may enter the case and cause corrosion or seizure of mechanical parts.
11. Avoid high frequency or ultrasonic vibrations on the relays as these can cause contact welding and misalignment or destruction of internal structures.
12. During operation, storage and transport, ambient temperature should be within the specified operating temperature range. Humidity should be in the range of 5% to 85% RH. Icing and condensation must be avoided. Relays stored for an extended period of time may show initially increased contact resistance values due to chemical effects such as oxidation.

Design guidelines

13. The relay may pull in and operate with less than the specified *must operate* voltage value.
14. The coil's *must operate* and *min. holding* voltages, the coil's *ohmic resistance* and the relay's *operate time* depend on the temperature of the coil. The specified values are given for a coil temperature of 23°C and increase by approx. 0.39% per Kelvin of temperature rise. This circumstance must be considered, especially during operation with high load currents and elevated ambient temperature.
15. At elevated ambient temperatures, after applying the rated nominal coil voltage for ≥ 200 milliseconds, the coil energization must be reduced to a suitable holding level in order to reduce thermal stress and to prevent the coil from overheating.
16. Coil suppression circuits such as diodes, etc. in parallel to the coil will lengthen the release time. We recommend using suppression circuits with a breakdown voltage of approx. 2 times the nominal coil voltage in order to achieve a quick release time.
17. When using PWM coil control, use a fast-switching recirculation diode in parallel with the coil to keep the coil current during pulse pauses. To achieve a quick release time when de-energizing the coil, the recirculation diode must be eliminated from the circuit to get a fast decay of coil current. As PWM frequency we recommend ≥ 15 kHz in order to avoid audible noise from magnetostriction. To reduce negative EMI effects, we recommend to apply the PWM to the coil's inner/center layer terminal and have the outer layer terminal connected to ground or the supply rail.
18. Contact resistance is a function of load current, dwell time and wear level of the contacts. Immediately after closing the contacts, or if tested with low current only, the contact resistance will show a relatively high value. A low level steady state contact resistance is reached at higher current after a certain time in thermal equilibrium.
19. The relay dissipates heat from power losses through its load terminals. Provide sufficient cross section and area of the PCB traces so that they can act as heat spreader.
20. For PCBs with multiple relays, do not place the components directly next to each other. We suggest providing a mounting distance of minimum 10 mm to allow for better cooling.
21. A minimum load of 10 mA / 5 V / 50 mW is recommended for the gold plated NC signal contact to ensure a reliable and stable electrical connection.
22. As with any contact mechanism, the relay's NC signal contact bounces when switching. For evaluation of its signal, suitable debouncing measures must be taken to get a reliable signal.

AZEV132

DISCLAIMER

This product specification is to be used in conjunction with the application notes which can be downloaded from the regional ZETTLER relay websites. The specification provides an overview of the most significant part features. Any individual applications and operating conditions are not taken into consideration. It is recommended to test the product under application conditions. Responsibility for the application remains with the customer. Proper operation and service life cannot be guaranteed if the part is operated outside the specified limits.

ZETTLER GROUP

Building on a foundation of more than a century of expertise in German precision engineering, ZETTLER Group is a world-class enterprise, engaged in the design, manufacturing, sales and distribution of electronic components. Our industry leadership is based on a unique combination of engineering competence and global scale.

For more information on other ZETTLER Group companies, please visit zettler-group.com. For support on this product or other ZETTLER relays, please visit one of the group sites below.

SITES FOR ZETTLER RELAYS

NORTH AMERICA

American Zettler, Inc.
www.azettler.com
sales@azettler.com

EUROPE

Zettler Electronics, GmbH
www.zettlerelectronics.com
office@zettlerelectronics.com

Zettler Electronics, Poland
www.zettlerelectronics.pl
office@zettlerelectronics.pl

CHINA

Zettler Group, China
www.zettlercn.com
relay@zettlercn.com

ASIA PACIFIC

Zettler Electronics (HK) Ltd.
www.zettlerhk.com
sales@zettlerhk.com



ZETTLER

www.ZETTLER-group.com

page 4 of 4

2024-11-20