

ZETTLER DISPLAYS

SPECIFICATIONS FOR LIQUID CRYSTAL DISPLAY

CUSTOMER APPROVAL			
※ PART NO. : ATM0177B3A-T (ZETTLER DISPLAYS) VER3.4			
APPROVAL		COMPANY CHOP	
CUSTOMER COMMENTS			

ZETTLER DISPLAYS ENGINEERING APPROVAL		
DESIGNED BY	CHECKED BY	APPROVED BY
Herbert	LH	GZH

REVISION RECORD

REVISION	REVISION DATE	PAGE	CONTENTS
VER1.0	2014-05-14		FIRST ISSUED
VER2.0	2014-07-10		CHANGE TP DIMENSION CORRECT DRIVING CURRENT
VER3.0	2015-04-22		CHANGE BACKLIGHT CIRCUIT
VER3.1	2015-05-29	14	ADD SOME DIMENSIONS
VER3.2	2015-06-02	14	MODIFY SOME DIMENSIONS
VER3.3	2016-08-18	15	ADD TP DRAWING AND PARAMETERS
		4	ADD RECOMMENDED CONNECTOR P/N
VER3.4	2016-09-14	4	CORRECT PIN5/12/14 DESCRIPTION

※ **CONTENTS**

1. GENERAL SPECIFICATIONS
2. PIN ASSIGNMENT
3. OPERATING SPECIFICATIONS
4. OPTICAL SPECIFICATIONS
5. RELIABILITY TEST
6. PRECAUTION FOR USING LCM
7. MECHANICAL DRAWING
8. TOUCH PANEL DRAWING

1. GENERAL SPECIFICATIONS

Item	Specification	Remark
1. LCD size	1.77 inch(Diagonal)	
2. Driver element	a-Si TFT active matrix	
3. Resolution	128x(RGB)x160	
4. Display mode	Normally white , Transmissive	
5. Dot Pitch (W*H)	0.073mm(W) x 0.219mm(H)	
6. Pixel pitch(W*H)	0.219mm(W) x 0.219mm(H)	
7. Active Area(W*H)	28.032mm(W) x 35.04mm(H)	
8. Module size (W*H)	34.70mm(W) x 46.7mm(H) x 3.75mm Max(D)	Note 1
9. Surface treatment	Clear	
10. Color arrangement	RGB-stripe	
11. Color	65K	
12. Contrller	ILI9163V	
13. Interface	4-wire SPI	
14. Weight	T.B.D.	
15. RoHS	RoHS compliant	

Note 1: Please refer to mechanical drawing.

2. PIN ASSIGNMENT

Recommended connector: Molex 0528921533 or compatible

Pin No.	Symbol	Function	Level	Note
1	XR	Right electrode of TP	I/O	
2	YD	Bottom electrode of TP	I/O	
3	XL	Left electrode of TP	I/O	
4	YU	Top electrode of TP	I/O	
5	A	Power for LED backlight(Anode)	P	
6	NC	No connection	--	
7	NC	No connection	--	
8	GND	Power ground	P	
9	VCC	Power supply	P	
10	SDA	Serial data	I/O	
11	SCK	Serial clock	I	
12	A0	Data/Command selection	I	
13	REST	Reset	I	
14	K	Power for LED backlight(Cathode)	P	
15	CS	Chip selection	I	

I: input, O: output, P: Power

3. Operating Specification

3.1 ABSOLUTE MAXIMUM RATINGS

Item	Symbol	Values		Unit	Remark
		Min.	Max.		
Power Voltage	V_{CC}	-0.3	4.6	V	
Operation Temperature	T_{OP}	-20	70	°C	
Storage Temperature	T_{ST}	-30	80	°C	
LED Reverse Voltage	V_R	-	1.2	V	Each LED Note 2
LED Forward Current	I_F		25	mA	Each LED

Note 1: The absolute maximum rating values of this product are not allowed to be exceeded at any times. Should a module be used with any of the absolute maximum ratings exceeded, the characteristics of the module may not be recovered, or in an extreme case, the module may be permanently destroyed.

Note 2: V_R Conditions: Zener Diode 20mA

3.1.1 Typical Operation Conditions

Item	Symbol	Values			Unit	Remark
		Min.	Typ.	Max.		
Power Voltage	V_{CC}	2.6	2.8	3.3	V	
Input Logic High Voltage	V_{IH}	$0.8V_{CC}$	--	V_{CC}	V	
Input Logic Low Voltage	V_{IL}	0	--	$0.2V_{CC}$	V	

3.1.2 Backlight driving conditions

Item	Symbol	Values			Unit	Remark
		Min.	Typ.	Max.		
Voltage for LED Backlight	V_L	2.9	3.2	3.3	V	
Current for LED Backlight	I_L	--	40	--	mA	
LED life time	--	30000	--	--	Hr	Note 1

Note 1: The "LED life time" is defined as the module brightness decrease to 50% original brightness at $T_a=25^\circ\text{C}$ and $I_L=40\text{mA}$.

3.3 Timing Characteristics

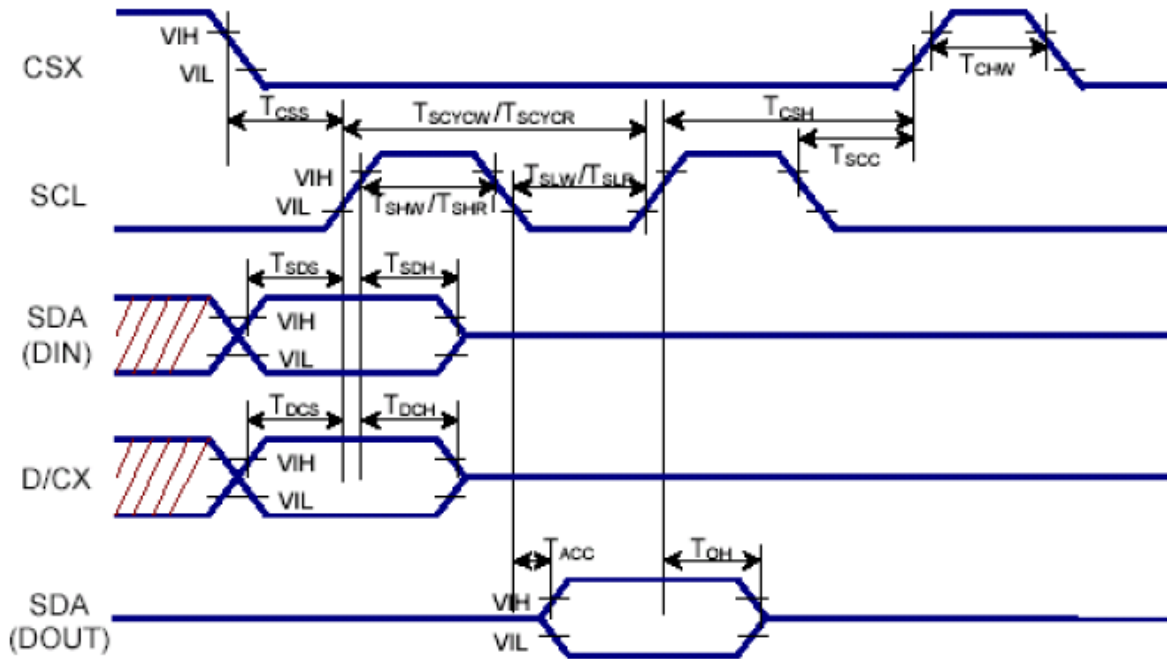

Signal	Symbol	Parameter	MIN	MAX	Unit	Description
CSX	T _{CSS}	Chip select setup time	15		ns	
	T _{CSH}	Chip select hold time	60		ns	
	T _{CHW}	Chip select setup time	40		ns	
SCL	T _{SCYCW}	Serial clock cycle(Write)	66		ns	
	T _{SHW}	SCL "H" pulse width(Write)	1		ns	
	T _{SLW}	SCL "L" pulse width(Write)	15		ns	
	T _{SCYCR}	Serial clock cycle(Read)	150		ns	
	T _{SHR}	SCL "H" pulse width(Read)	60		ns	
D/CX	T _{SLR}	SCL "L" pulse width(Read)	60		ns	
	T _{DCS}	D/CX setup time	7		ns	
SDA(DIN) (DOUT)	T _{DCH}	D/CX hold time	7		ns	
	T _{SDS}	Data setup time	10		ns	
	T _{SDH}	Data hold time	10		ns	
	T _{ACC}	Access time	10	50	ns	For maximum CL = 30pF
	T _{OH}	Output disable time	15		ns	For minimum CL = 8pF

Note 1: VDDI=1.65 to 3.3V, VDD=2.6 to 3.3V, AGND=GND=0V. Ta=-30 to 70°C (to +85°C no damage)

Note 2 : The input signal rise time and fall time(tr, tf) is specified at 15 ns or less.

Logic high and low levels are specified as 10% and 90% of VDDI for Input signals.

Reset Timing Characteristics (VCC = 1.8 ~ 3.3 V, IOVCC = 1.65 ~ 3.3 V)

Item	Symbol	Unit	Min.	Typ.	Max.
Reset low-level width	t_{RES}	ms	1	-	-
Reset rise time	t_{RES}	μ S	-	-	10

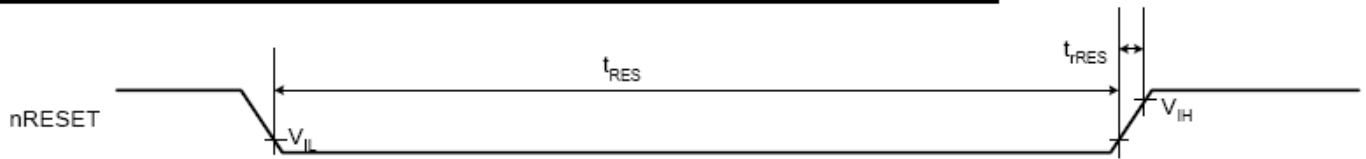

4.0 OPTICAL SPECIFICATIONS

Item	Symbol	Condition	Values			Unit	Remark
			Min.	Typ.	Max.		
Viewing Angle (CR≥10)	θ_L	$\Phi=180^\circ$ (9 O'CLOCK)	60	70	--	degree	Note 1
	θ_R	$\Phi=0^\circ$ (3 O'CLOCK)	60	70	--		
	θ_T	$\Phi=90^\circ$ (12 O'CLOCK)	30	40	--		
	θ_B	$\Phi=270^\circ$ (6 O'CLOCK)	20	30	--		
Response Time	T_{ON}	Normal $\Theta=\Phi=0^\circ$	--	10	20	msec	Note 3
	T_{OFF}		--	15	30	msec	Note 3
Contrast Ratio	CR		400	500	--	--	Note 4
Color Chromaticity	W_X		0.26	0.31	0.36	--	Note 2
	W_Y		0.28	0.33	0.38	--	Note 5 Note 6
Luminance	L		360	--	--	cd/m ²	Note 6
Luminance Uniformity	YU		75	80	--	%	Note 7

Test Conditions:

1. If=40mA, the ambient temperature is 25°C.
2. The test systems refer to Note 2.

Note 1: Definition of viewing angle range

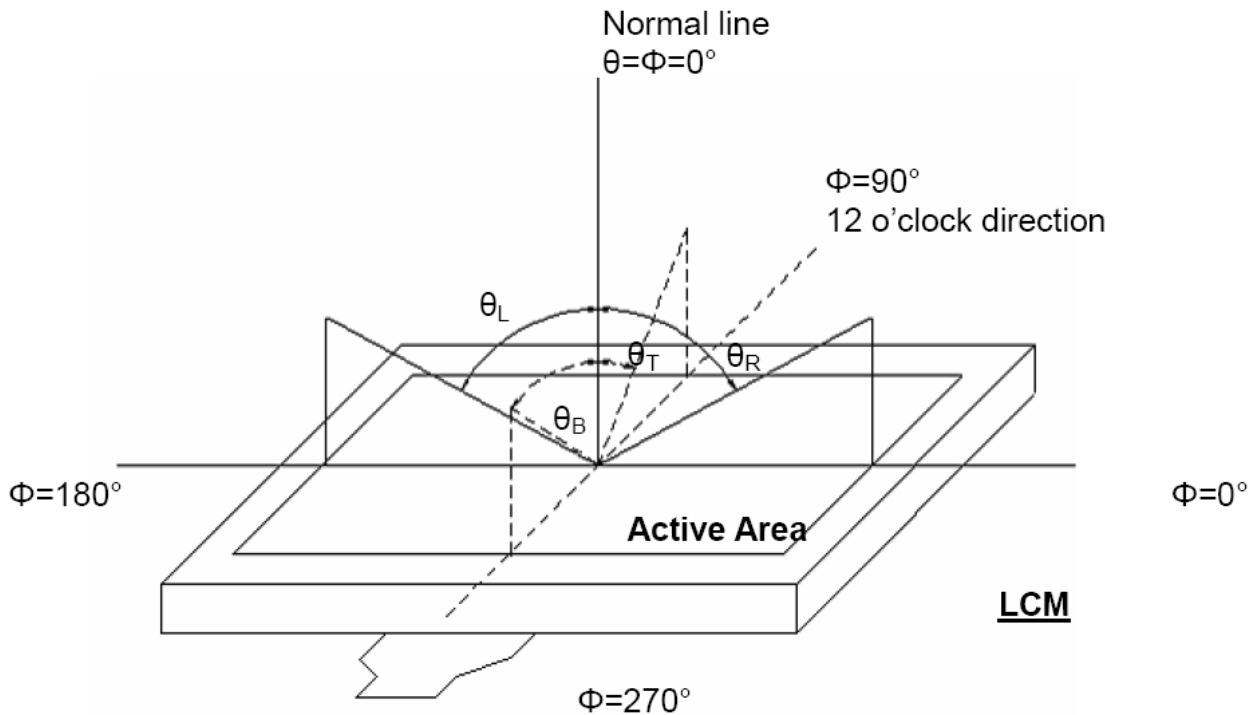

Figure 4.1 Definition of viewing angle.

Note 2: Definition of optical measurement system.

The optical characteristics should be measured in dark room. After 30 minutes operation, the optical properties are measured at the center point of the LCD screen. (Response time is measured by Photo detector TOPCON)

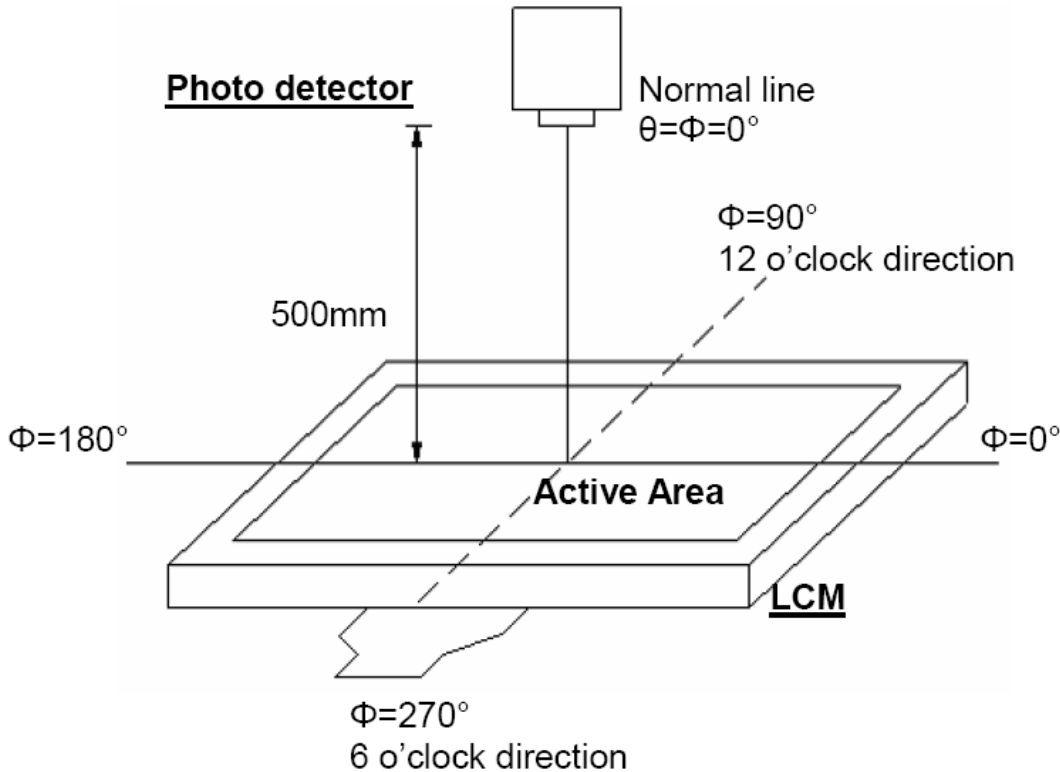

Figure 4.2 Optical measurement system setup

Note 3: Definition of Response time

The response time is defined as the LCD optical switching time interval between "White" state and "Black" state. Rise time (T_{ON}) is the time between photo detector output intensity changed from 90% to 10%. And fall time (T_{OFF}) is the time between photo detector output intensity changed from 10% to 90%.

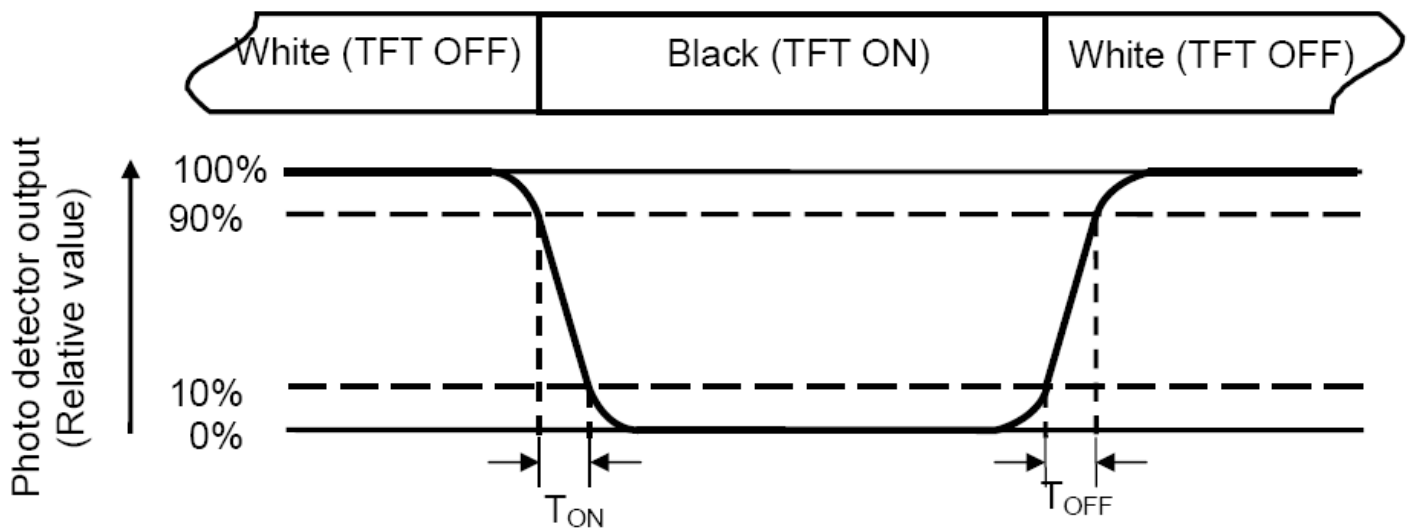

Figure 4.3 Definition of response.

Note 4: Definition of contrast ratio

$$\text{Contrast ratio(CR)} = \frac{\text{Luminance measured when LCD on the "white" state}}{\text{Luminance measured when LCD on the "black" state}}$$

Note 5: Definition of color chromaticity (CIE1931)

Color coordinates measured at center point of LCD.

Note 6: All input terminals LCD panel must be ground while measuring the center area of the panel.

Note 7: Definition of Luminance Uniformity

Active area is divided into 9 measuring areas (Refer to Fig. 4-4).Every measuring point is placed at the center of each measuring area.

$$\text{Luminance Uniformity (Yu)} = \frac{B_{min}}{B_{max}}$$

L-----Active area length W----- Active area width

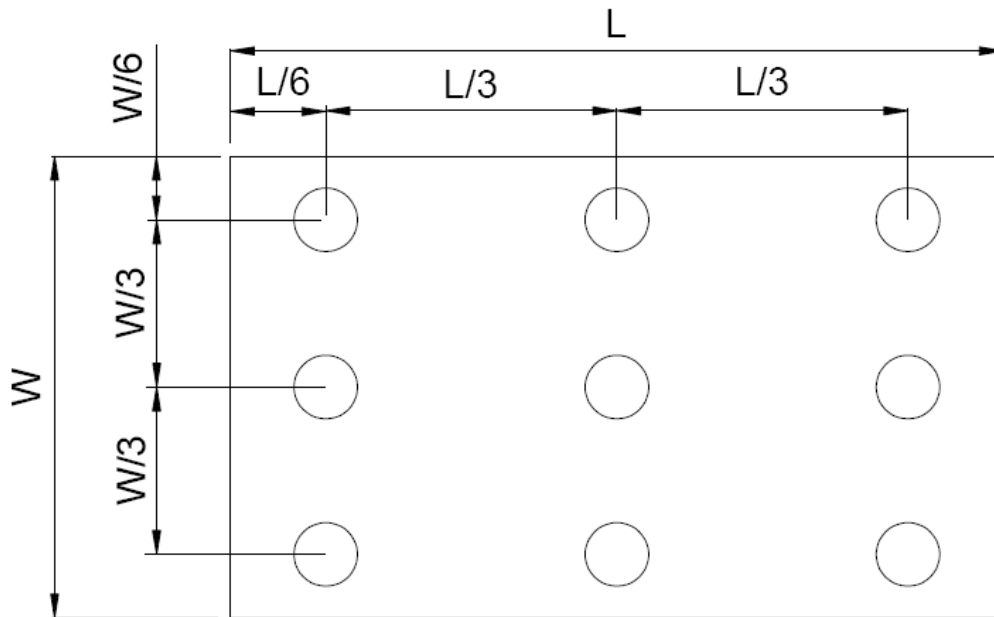

Figure 4.3 Definition of measuring points.

Bmax: The measured maximum luminance of all measurement position.

Bmin: The measured minimum luminance of all measurement position.

5. RELIABILITY TEST

Item	Test Condition Item	Remark
High temperature storage	Ta= 70 °C 240hrs	Note 1 Note 4
Low temperature storage	Ta=-20 °C 240hrs	Note 1 Note 4
High temperature operation	Ts= 60 °C 240hrs	Note 2 Note 4
Low temperature operation	Ts=-10 °C 240hrs	Note 1 Note 4
High temperature/High humidity operation	90% RH 40°C 120hrs	Note 4
Thermal Shock	-1°C/30 min ~ +6°C/30 min for a total 10 cycles, Start with cold temperature and end with high temperature.	Note 4
Package drop test	Height:100 cm 1 corner, 3 edges, 6 surfaces	

Note 1: Ta is the ambient temperature of samples.

Note 2: Ts is the temperature of panel's surface.

Note 3: In the standard condition, there shall be no practical problem that may affect the display function. After the reliability test, the product only guarantees operation, but don't guarantee all of the cosmetic specification.

Note 4: Before cosmetic and function test, the product must have enough recovery time, at least 2 hours at room temperature.

6. PRECAUTION FOR USING LCM

1. When design the product with this LCD Module, make sure the viewing angle matches to its purpose of usage.
2. As LCD panel is made of glass substrate, Dropping the LCD module or banging it against hard objects may cause cracking or fragmentation. Especially at corners and edges.
3. Although the polarizer of this LCD Module has the anti-glare coating, always be careful not to scratch its surface. Use of a plastic cover is recommended to protect the surface of polarizer.
4. If the LCD module is stored at below specified temperature, the LC material may freeze and be deteriorated. If it is stored at above specified temperature, the molecular orientation of the LC material may change to Liquid state and it may not revert to its original state. Excessive temperature and humidity could cause polarizer peel off or bubble. Therefore, the LCD module should always be stored within specified temperature range.
5. Saliva or water droplets must be wiped off immediately as those may leave stains or cause color changes if remained for a long time. Water vapor will cause corrosion of ITO electrodes.
6. If the surface of LCD panel needs to be cleaned, wipe it swiftly with cotton or other soft cloth. If it is not still clean enough, blow a breath on the surface and wipe again.
7. The module should be driven according to the specified ratings to avoid malfunction and permanent damage. Applying DC voltage cause a rapid deterioration of LC material. Make sure to apply alternating waveform by continuous application of the M signal. Especially the power ON/OFF sequence should be kept to avoid latch-up of driver LSIs and DC charge up to LCD panel.
8. Mechanical Considerations
 - a) LCM are assembled and adjusted with a high degree of precision. Avoid excessive shocks and do not make any alterations or modifications. The following should be noted.
 - b) Do not tamper in any way with the tabs on the metal frame.
 - c) Do not modify the PCB by drilling extra holes, changing its outline, moving its components or modifying its pattern.
9. Static Electricity
 - a) Operator

Wear the electrostatics shielded clothes because human body may be statically charged if not ware shielded clothes. Never touch any of the conductive parts such as the LSI pads; the copper leads on the PCB and the interface terminals with any parts of the human body.

- b) Equipment

There is a possibility that the static electricity is charged to the equipment, which has a function of peeling or friction action (ex: conveyer, soldering iron, working table). Earth the equipment through proper resistance (electrostatic earth: 1×10^8 ohm).

Only properly grounded soldering irons should be used.

If an electric screwdriver is used, it should be well grounded and shielded from commutator sparks.

The normal static prevention measures should be observed for work clothes and working benches; for the latter conductive (rubber) mat is recommended.

- c) Floor

Floor is the important part to drain static electricity, which is generated by operators or equipment.

There is a possibility that charged static electricity is not properly drained in case of insulating floor. Set the electrostatic earth (electrostatic earth: 1×10^8 ohm).

- d) Humidity

Proper humidity helps in reducing the chance of generating electrostatic charges. Humidity should be kept over 50%RH.

- e) Transportation/storage

The storage materials also need to be anti-static treated because there is a possibility that the human body or storage materials such as containers may be statically charged by friction or peeling.

The modules should be kept in antistatic bags or other containers resistant to static for storage.

- f) Soldering

Soldering anything to this TFT display would void the warranty.

- g) Others

The laminator (protective film) is attached on the surface of LCD panel to prevent it from scratches or stains. It should be peeled off slowly using static eliminator.

Static eliminator should also be installed to the workbench to prevent LCD module from static charge.

10. Operation

- a) Driving voltage should be kept within specified range; excess voltage shortens display life.
- b) Response time increases with decrease in temperature.
- c) Display may turn black or dark blue at temperatures above its operational range; this is (however not pressing on the viewing area) may cause the segments to appear "fractured".
- d) Mechanical disturbance during operation (such as pressing on the viewing area) may cause the segments to appear "fractured".

11. If any fluid leaks out of a damaged glass cell, wash off any human part that comes into contact with soap and water. The toxicity is extremely low but caution should be exercised at all the time.
12. Disassembling the LCD module can cause permanent damage and it should be strictly avoided.
13. LCD retains the display pattern when it is applied for long time (Image retention). To prevent image retention, do not apply the fixed pattern for a long time. Image retention is not a deterioration of LCD. It will be removed after display pattern is changed.
14. Do not use any materials, which emit gas from epoxy resin (hardener for amine) and silicone adhesive agent (dealcohol or deoxym) to prevent discoloration of polarizer due to gas.
15. Avoid the exposure of the module to the direct sunlight or strong ultraviolet light for a long time.

7. MECHANICAL DRAWING

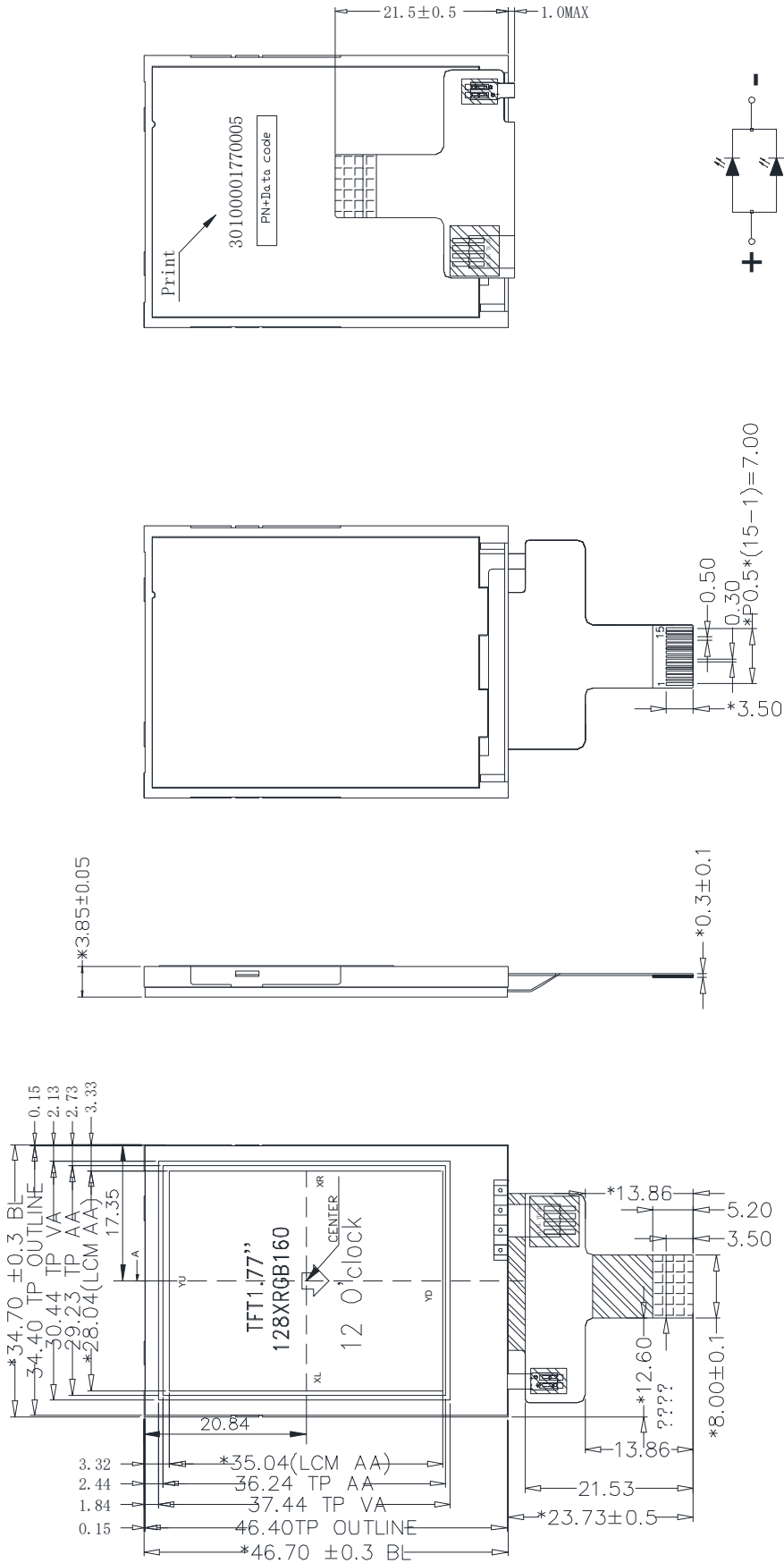

LED CIRCUIT DIAGRAM

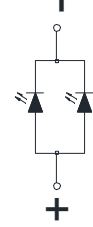

8. TOUCH PANEL DRAWING

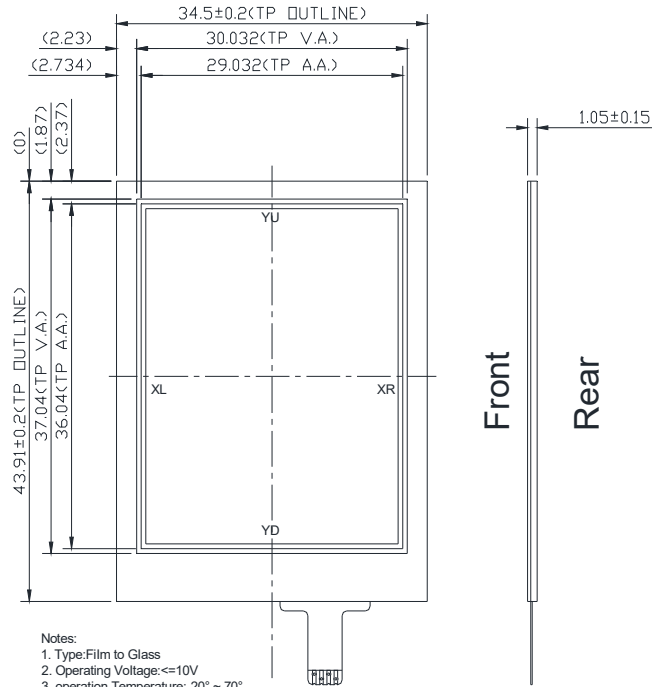

- Notes:
1. Type: Film to Glass
 2. Operating Voltage: ≤10V
 3. operation Temperature: -20° ~ 70°
Storage Temperature: -30° ~ 80°
 4. Connect Material: FPC
 5. Response Time: <15ms
 - 6 Linearity: <3%
 7. Transmittance: >80%
 8. Surface Hardness: >3H(Pencil)
 9. Resistance: X: 450~900 Ohms
Y: 200~500 Ohms
 10. operation force: 50 ~ 120g